

Q. 1 – Q20 carry one mark each.

1. If $z = x + jy$, where x and y are real, the value of $|e^{jz}|$ is
(A) 1 (C) e^Y
(B) $e^{\sqrt{x^2 + y^2}}$ (D) e^{-Y}
2. The value of $\oint \frac{\sin Z}{Z} dZ$, where the contour of integration is a simple closed curve around the origin, is
(A) 0 (C) ∞
(B) $2\pi j$ (D) $1/(2\pi j)$
3. Let $P \neq 0$ be a 3×3 real matrix. There exist linearly independent vectors x and y such that $Px = 0$ and $Py = 0$. The dimension of the range space of P is
(A) 0 (C) 2
(B) 1 (D) 3
4. A sphere of unit radius is centered at the origin. The unit normal at a point (x, y, z) on the surface of the sphere is the vector
(A) (x, y, z)
(B) $\left(\frac{1}{\sqrt{3}}, \frac{1}{\sqrt{3}}, \frac{1}{\sqrt{3}}\right)$
(C) $\left(\frac{x}{\sqrt{3}}, \frac{y}{\sqrt{3}}, \frac{z}{\sqrt{3}}\right)$
(D) $\left(\frac{x}{\sqrt{2}}, \frac{y}{\sqrt{2}}, \frac{z}{\sqrt{2}}\right)$
5. An LVDT is supplied with a sinusoidal voltage of amplitude 5V and frequency 1kHz. The output is connected to an ac voltmeter. The reading of the voltmeter is 1V for a displacement of 1mm from the null position. When the displacement is 1mm in the opposite direction from the null position, the reading of the voltmeter is
(A) $-1V$ (C) 1V
(B) $-0.2V$ (D) 5V
6. The circuit shown is the figure is

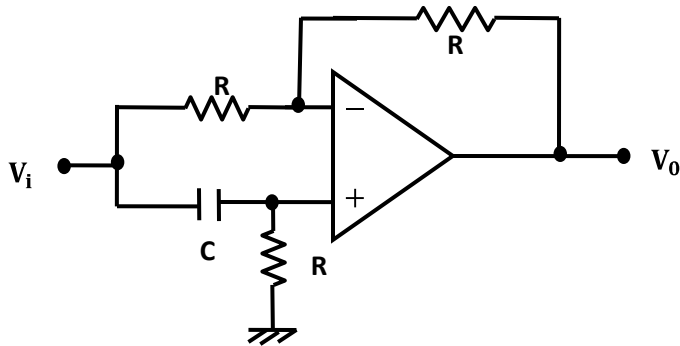

- (A) an all-pass filter
- (B) a bandpass filter
- (C) a highpass filter
- (D) a lowpass filter

7. The diodes in the circuit shown are ideal. A voltage of 0V represents logic 0 and +5V represents logic 1. The logic function Z realized by the circuit for logic inputs X and Y is

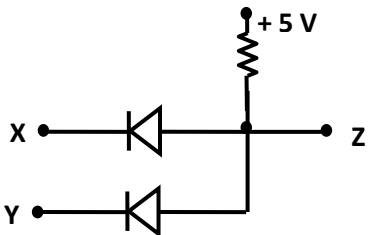

- (A) $Z = X = Y$
- (B) $Z = XY$
- (C) $Z = \overline{X + Y}$
- (D) $Z = \overline{XY}$

8. The minimal sum-of-products expression for the logic function f represented by the given Karnaugh map is

		PQ			
	RS	00	01	11	10
00		0	1	0	0
01		0	1	1	1
11		1	1	1	0
10		0	0	1	0

- (A) $QS + P\bar{R}S + PQR + \bar{P}RS + \bar{P}Q\bar{R}$
 (B) $\bar{Q}S + \bar{P}R\bar{S} + \bar{P}Q\bar{R} + P\bar{R}\bar{S} + P\bar{Q}R$
 (C) $\bar{P}R\bar{S} + \bar{P}\bar{Q}\bar{R} + P\bar{R}\bar{S} + P\bar{Q}R$
 (D) $\bar{P}R\bar{S} + PQR + \bar{P}RS + \bar{P}QR + \bar{P}Q\bar{R}$

9. In the figure shown, the initial state of Q is 0. The output is observed after the application of each clock pulse. The output sequence at Q is

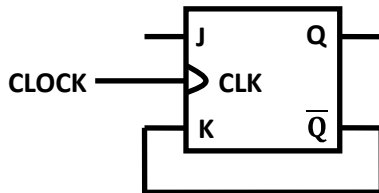

- (A) 0000...
 (B) 1010...
 (C) 1111...
 (D) 1000...
10. The binary representation of the decimal number 1.375 is
 (A) 1.111
 (B) 1.010
 (C) 1.011
 (D) 1.001
11. Consider a system consisting of a microprocessor, memory, and peripheral devices connected by a common bus. During DMA data transfer, the microprocessor
 (A) only read from the bus
 (B) only write to the bus
 (C) both read from and writes to the bus
 (D) neither read from nor writes to the bus
12. The fundamental period of $x(t) = 2\sin \pi t + 3\sin 3\pi t$, with t expressed in seconds, is
 (A) 1s
 (B) 0.67s
 (C) 2s
 (D) 3s
13. A linear time-invariant causal system has a frequency response given in polar form as $\frac{1}{\sqrt{1+\omega^2}} \angle \tan^{-1} \omega$. For input $x(t) = \sin t$, the output is
 (A) $\frac{1}{\sqrt{2}} \cos t$
 (B) $\frac{1}{\sqrt{2}} \cos t \left(t - \frac{\pi}{4} \right)$
 (C) $\frac{1}{\sqrt{2}} \sin t$
 (D) $\frac{1}{\sqrt{2}} \sin \left(t - \frac{\pi}{4} \right)$

14. A 50% duty cycle square wave with zero mean is used as a baseband signal in an ideal frequency modulator with a sinusoidal carrier of frequency ω_c . The modulated signal is given as an input to an ideal phase demodulator (a circuit that produces an output proportional to the difference in phase of the modulated signal from that of the carrier). The output of the circuit is
- (A) a square wave (C) a triangular wave
(B) a train of impulses with alternating signs (D) a sinusoidal wave

15. The figure shows a periodic waveform to be displayed on a CRO. A trigger setting which ensures a stationary display is

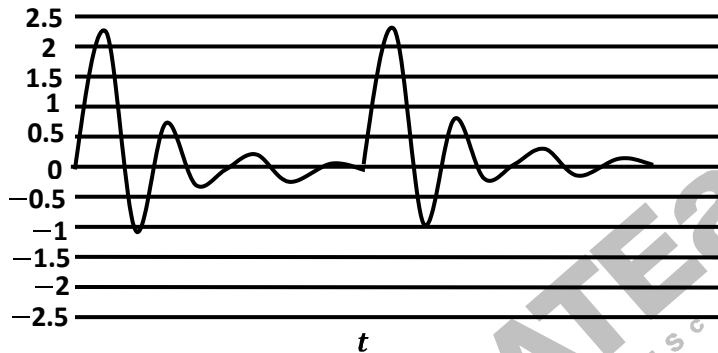

- (A) level: 0.2V, slope:- ve (C) level: -0.2V, slope: + ve
(B) level: 0.5V, slope:- ve (D) level: 1.8V, slope:- ve
16. The input impedance of CRO is equivalent to a $1\text{M}\Omega$ resistance in parallel with a 45pF capacitance. It is used with a compensated 10-to-1 attenuation probe. The effective input capacitance at the probe tip is
- (A) 4.5pF (C) 45pF
(B) 5pF (D) 450pF
17. A galvanometer with internal resistance 100Ω and full-scale current 1mA is used to realize a dc voltmeter with a full scale range of 1V . The full scale range of this voltmeter can be extended to 10V by connecting an external resistance of value
- (A) $9\text{k}\Omega$ (C) $10\text{k}\Omega$
(B) $9.9\text{k}\Omega$ (D) $11\text{k}\Omega$
18. A plant with a transfer function $\frac{2}{s(s+3)}$ is controlled by a PI controller with $K_p = 1$ and $K_i \geq 0$ in a unity feedback configuration. The lowest value of K_i that ensures zero steady state error for a step change in the reference input is

- (A) 0 (C) 1/2
(B) 1/3 (D) 1
19. A mass spectrometer is to be used to resolve peaks corresponding to CO^+ and N_2^+ . The atomic masses are $^{12}\text{C}=12.0000$, $^{16}\text{O} = 15.9949$, and $^{14}\text{N} = 14.0031$ amu. The resolving power of the mass spectrometer should be at least
- (A) 250 (C) 2500
(B) 350 (D) 3500
20. Assuming complete dissociation, the pH of a 1mM solution of H_2SO_4 is closest to
- (A) 0 (C) 2.4
(B) 2.7 (D) 2.1
21. The eigen values of a (2×2) matrix X are -2 and -3 . The eigenvalues of matrix $(X + I)^{-1}(X + 5I)$ are
- (A) $-3, -4$ (C) $-1, -3$
(B) $-1, -2$ (D) $-2, -4$
22. The matrix $P = \begin{bmatrix} 0 & 0 & 1 \\ 1 & 0 & 0 \\ 0 & 1 & 0 \end{bmatrix}$ rotates a vector about the axis $\begin{bmatrix} 1 \\ 1 \\ 1 \end{bmatrix}$ by an angle of
- (A) 30° (C) 90°
(B) 60° (D) 120°
23. A screening test is carried out to detect a certain disease. It is found that 12% of the positive reports and 15% of the negative reports are incorrect. Assuming that the probability of a person getting a positive report is 0.01, the probability that a person tested gets an incorrect report is
- (A) 0.0027 (C) 0.1497
(B) 0.0173 (D) 0.2100
24. One of the roots of the equation $x^3 = j$, where j is the positive square root of -1 , is
- (A) j
(B) $\frac{\sqrt{3}}{2} + j\frac{1}{2}$
(C) $\frac{\sqrt{3}}{2} - j\frac{1}{2}$
(D) $-\frac{\sqrt{3}}{2} - j\frac{1}{2}$

25. The differential equation $\frac{dx}{dt} = \frac{4-x}{\tau}$, with $x(0) = 0$, and the constant $\tau > 0$, is to be numerically integrated using the forward Euler method with a constant integration time step T . The maximum value of T such that the numerical solution of x converges is
- (A) $\tau / 4$ (C) τ
 (B) $\tau / 2$ (D) 2τ
26. A quantity x is calculated by using the formula, $x = \frac{(p-q)}{r}$. The measured values are $p = 9, q = 6, r = 0.5$. Assume that the measurement errors in p, q and r are independent. The absolute maximum error in the measurement of each of the three quantities is ε . The absolute maximum error in the calculated value of x is
- (A) ε (C) 3ε
 (B) 2ε (D) 16ε
27. The response of a first order measurement system to a unit step input is $1 - e^{-0.5t}$, where t is in seconds. A ramp of 0.1 units per second is given as the input to this system. The error in the measured value after transients have died down is
- (A) 0.02 units (C) 0.2 units
 (B) 0.1 units (D) 1 unit
28. The source network S is connected to the load network L as shown by dashed lines. The power transferred from S to L would be maximum when R_L is

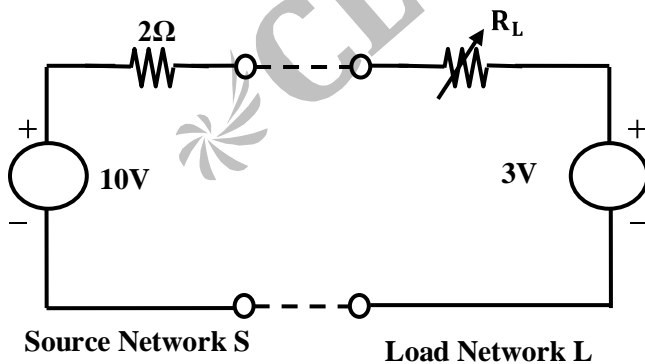

- (A) 0Ω (C) 0.8Ω
 (B) 0.6Ω (D) 2Ω

29. A stroboscopic system is used for measuring the speed of a rotating shaft. The shaft has one target mark on it. The maximum strobe rate at which synchronism is achieved is r_1 flashes per minute. The next lower flash rate at which synchronism is achieved is r_2 flashes per minute. The speed of the shaft in rpm is

- (A) $\frac{r_1 r_2}{r_1 - r_2}$
 (B) $\frac{r_1 r_2}{r_1 + r_2}$
 (C) $\frac{r_2^2}{r_1 + r_2}$
 (D) $\frac{r_1^2}{r_1 + r_2}$

30. The figure shows the cross-sectional diagram of an orifice flow meter with an orifice radius R . Point 'a' is $30R$ upstream while points 'b' and 'c' are $0.8R$ and $30R$ downstream from the orifice respectively. The pressures at points a, b and c are P_a , P_b and P_c respectively. Then

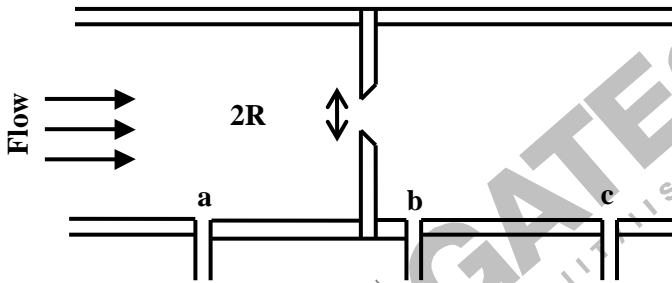

(Figure not to scale)

- (A) $P_c > P_b > P_a$
 (B) $P_b > P_c > P_a$
 (C) $P_a > P_b > P_c$
 (D) $P_a > P_c > P_b$
31. The values of the material constant β for thermistors P and Q are 4000 K and 3000 K, respectively. The resistance of each thermistor at 298 K is $2\text{k}\Omega$. At 373 K the ratio of the resistance of thermistor P to that of thermistor Q will be closest to
- (A) 1.33
 (B) 1.00
 (C) 0.75
 (D) 0.50
32. Four strain gauges are fixed on a cylindrical shaft to measure torque, as shown in the figure.

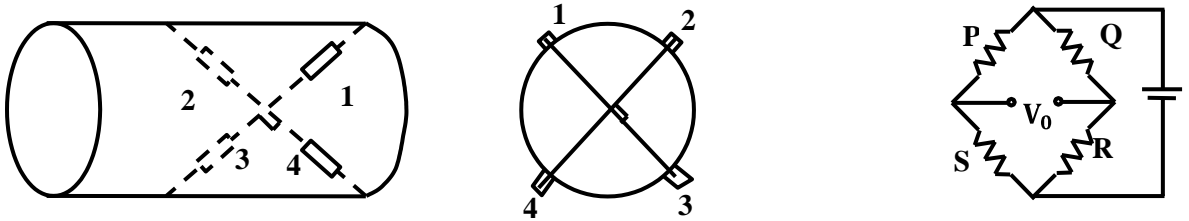

A correct way to place these gauges in the bridge is

- (A) P – 1, Q – 2, R – 3, S – 4
- (B) P – 1, Q – 3, R – 2, S – 4
- (C) P – 3, Q – 1, R – 2, S – 4
- (D) P – 2, Q – 1, R – 3, S – 4

33. In the circuit shown, the Zener diode has ideal characteristics and a breakdown voltage of 3.2V. The output voltage V_o for an input voltage $V_i = +1V$ is closest to

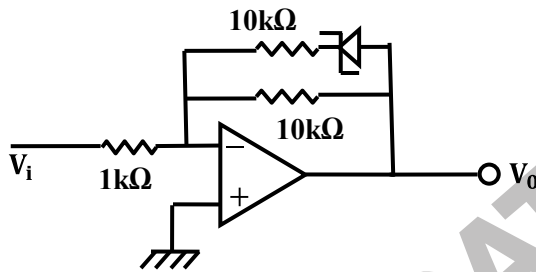

- (A) -10V
- (B) -6.6V
- (C) -5V
- (D) -3.2V

34. The input resistance of the circuit shown in the figure, assuming an ideal op amp, is

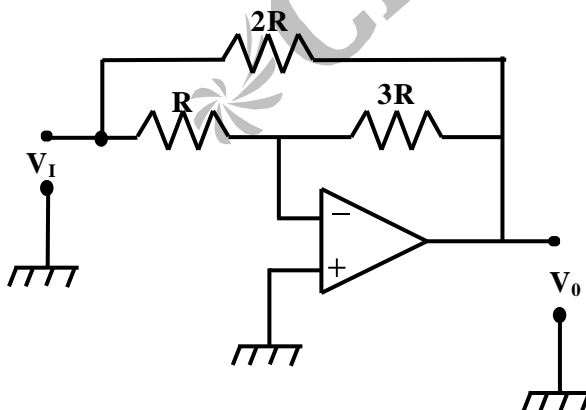

- (A) $R/3$
- (B) $2R/3$
- (C) R
- (D) $4R/3$

35. In the circuit shown in the figure, the switch S has been in Position 1 for a long time. It is then moved to Position 2. Assume the Zener diodes to be ideal. The time delay between the switch moving to Position 2 and the transition in the output voltage V_o is

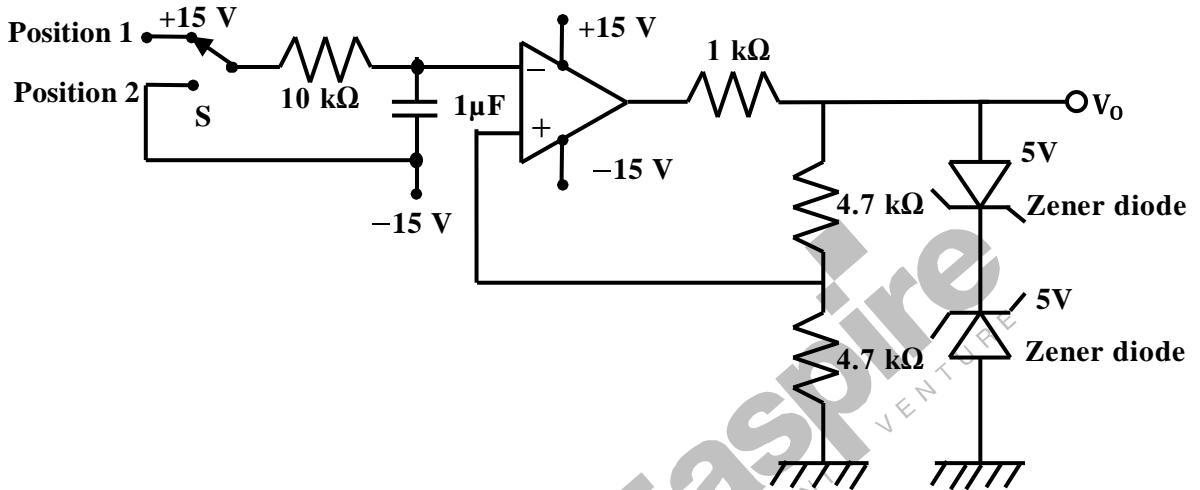

- (A) 5.00ms (B) 8.75ms (C) 10.00ms (D) 13.75ms

36.

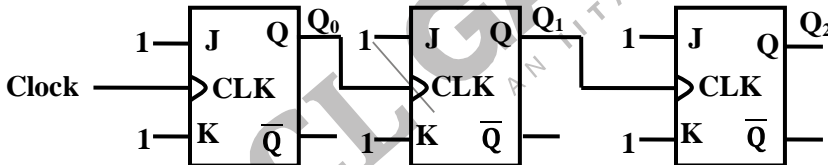

The figure above shows a 3-bit ripple counter, with Q_2 as the MSB. The flip-flops are rising-edge triggered. The counting direction is

- (A) always down
 (B) always up
 (C) up or down depending on the initial state of Q_0 only
 (D) up or down depending on the initial states of Q_2, Q_1 and Q_0

37. An 8-bit ADC, with 2's complement output, has a nominal input range of $-2V$ to $+2V$. It generates a digital code of 00H for an analog input in the range $-7.8125mV$ to $+7.815mV$. An input of $-1.5V$ will produce a digital output of

- (A) 90H (B) 96H (C) 9BH (D) A0H

38. The following is an assembly language program for 8085 microprocessors:

Address	Instruction Code	Mnemonic
1000H	3E06	MVI A, 06H
1002H	C6 70	ADI 70H
1004H	32 07 10	STA 1007H
1007H	AF	XRA
1008H	76	HLT

When this program halts, the accumulator contains

- (A) 00H (C) 70H
(B) 06H (D) 76H

39. For input $x(t)$, an ideal impulse sampling system produces the output

$$y(t) = \sum_{k=-\infty}^{\infty} x(kT)\delta(t - kT)$$

where $\delta(t)$ is the Dirac delta function.

The system is

- (A) nonlinear and time invariant (C) linear and time invariant
(B) nonlinear and time varying (D) linear and time varying

40. The root mean squared value of $x(t) = 3 + 2\sin(t) \cos(2t)$ is

- (A) $\sqrt{3}$ (C) $\sqrt{10}$
(B) $\sqrt{8}$ (D) $\sqrt{11}$

41. An analog signal is sampled at 9kHz. The sequence so obtained is filtered by an FIR filter with transfer function $H[z] = 1 - z^{-6}$. One of the analog frequencies for which the magnitude response of the filter is zero is

- (A) 0.75kHz (C) 1.5kHz
(B) 1kHz (D) 2kHz

42. The transfer function $H(z)$ of a fourth-order linear phase FIR system is given by

$$H[z] = (1 + 2z^{-1} + 3z^{-2}), G(z)$$

Then $G(z)$ is

- (A) $3 + 2z^{-1} + z^{-2}$ (C) $\frac{1}{3} + 2z^{-1} + z^{-2}$
(B) $1 + \frac{1}{2}z^{-1} + \frac{1}{3}z^{-2}$ (D) $1 + 2z + 3z^2$

43. The dc potentiometer shown in the figure has a working current of 10mA with switch S open. Let $R_g + R_1 = 100\Omega$. The galvanometer G can only detect currents greater than $10 \mu A$. The maximum percentage error in the measurement of the unknown emf E_x as calculated from the slider position shown is closest to

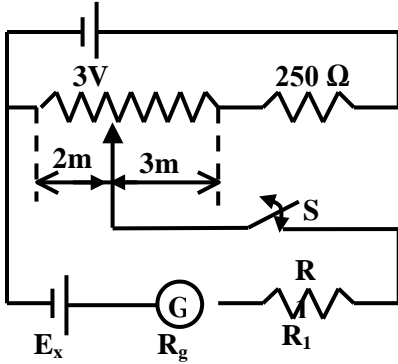

- (A) 0.3
 (B) 0.5
 (C) 0.6
 (D) 1.0
44. A filter is represented by the signal flow graph shown in the figure. Its input is $x(t)$ and output is $y(t)$. The transfer function of the filter is

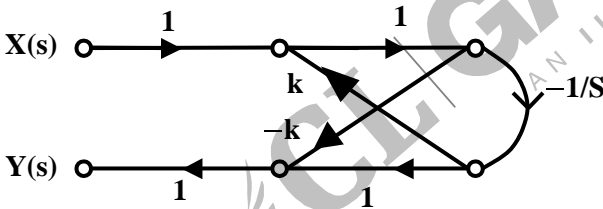

- (A) $\frac{-(1+KS)}{S+K}$
 (B) $\frac{(1-KS)}{S-K}$
 (C) $\frac{-(1-KS)}{S+K}$
 (D) $\frac{(1-KS)}{S+K}$
45. A unity feedback control loop with an open transfer function of the form $\frac{K}{s(s+a)}$ has a gain crossover frequency of 1 rad/s and a phase margin of 60° . If an element having a transfer function $\frac{s-\sqrt{3}}{s+\sqrt{3}}$ is inserted into the loop, the phase margin will become

- (A) 0°
 (B) 30°
 (C) 45°
 (D) 60°

46. A linear time-invariant single-input single-output system has a state space model given by

$$\frac{dx}{dt} = Fx + Gu; y = Hz$$

where $F = \begin{bmatrix} 0 & 1 \\ -4 & -2 \end{bmatrix}$; $G = \begin{bmatrix} 0 \\ 1 \end{bmatrix}$; $H = [1 \ 0]$.

Here x is the state vector, u is the input, and y is the output.

The damping ratio of the system is

- (A) 0.25 (C) 1
(B) 0.5 (D) 2
47. A unity feedback system has the transfer function $\frac{K(s+b)}{s^2(s+20)}$
The value are for which the loci of all the three roots of the closed loop characteristic equation meet at a single point is
(A) 10/9 (C) 30/9
(B) 20/9 (D) 40/9
48. A standard three-lead frontal plane ECG is taken of a person with a normal heart. The peak amplitude of the R-wave is
(A) greatest in lead I (C) greatest in lead III
(B) greatest in lead II (D) equal in all the leads
49. The operating voltage of an X-ray tube is changed from 40kV to 50kV. The resulting change in the shortest wavelength generated is
(A) +20% (C) +25%
(B) -20% (D) -36%
50. In a pulsed ultrasound imaging system, a single 5MHz crystal is used both as source and as detector. Bursts of at least 20 cycles are needed for acceptable image quality. The velocity of sound in the tissue being imaged is 1500m/s. The minimum distance of the objects to be imaged should be
(A) 12mm (C) 1mm
(B) 6mm (D) 3mm

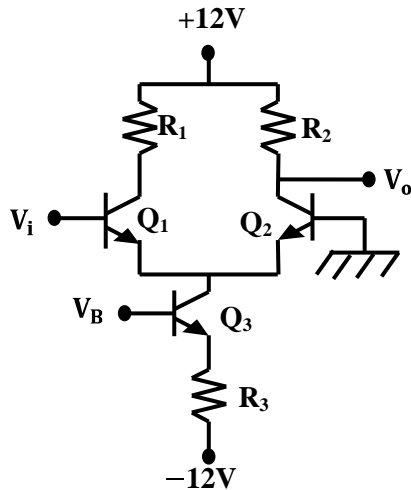

53. The bias voltage V_B at the base of the transistor Q_3 is approximately
- (A) -9.3V (C) -10.3V
 (B) -10.0V (D) -11.0V
54. The small signal voltage gain of the circuit is
- (A) -20 (C) 20
 (B) -40 (D) 40

Common Data for Questions 55 and 56:

The figure shows an arrangement for measuring small angular displacements in a vertical plane. A non-conducting tube of length $2l$ and rectangular cross section (width w , height d) is bent along an arc of a circle with radius $R \gg d$, centered at P . Four electrode plates of length l and width w are placed to form two curved parallel plate capacitors C_1 and C_2 with a negligible gap between them. The tube contains water with an air bubble of rectangular cross section (width w , height d) and length $l/4$. The capacitors are connected in a bridge circuit as shown in the figure, where the bridge has ac excitation V_i . Angular displacement $\Delta\theta$ occurs about the point P .

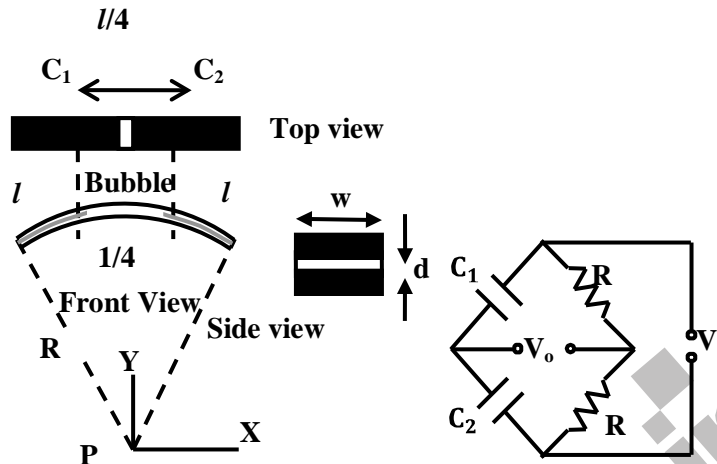

55. The range of angular displacement (in radians) this system can measure is

- (A) $-\frac{l}{8R}$ to $+\frac{l}{8R}$ (C) $-\frac{3l}{4R}$ to $+\frac{l}{4R}$
 (B) $-\frac{l}{4R}$ to $+\frac{l}{4R}$ (D) $-\frac{l}{R}$ to $+\frac{l}{R}$

56. The sensitivity $\frac{v_o/v_i}{\Delta\theta}$ is

- (A) inversely proportional to R and l
 (B) inversely proportional to R and directly proportional to l
 (C) directly proportional to R and l
 (D) directly proportional to R and inversely proportional to l

Common Data for Questions 57 to 58:

Statement for Linked Answer Questions 57 and 58:

A disturbance input $d(t)$ is injected into the unity feedback control loop shown in the figure. Take the reference input $r(t)$ to be a unit step.

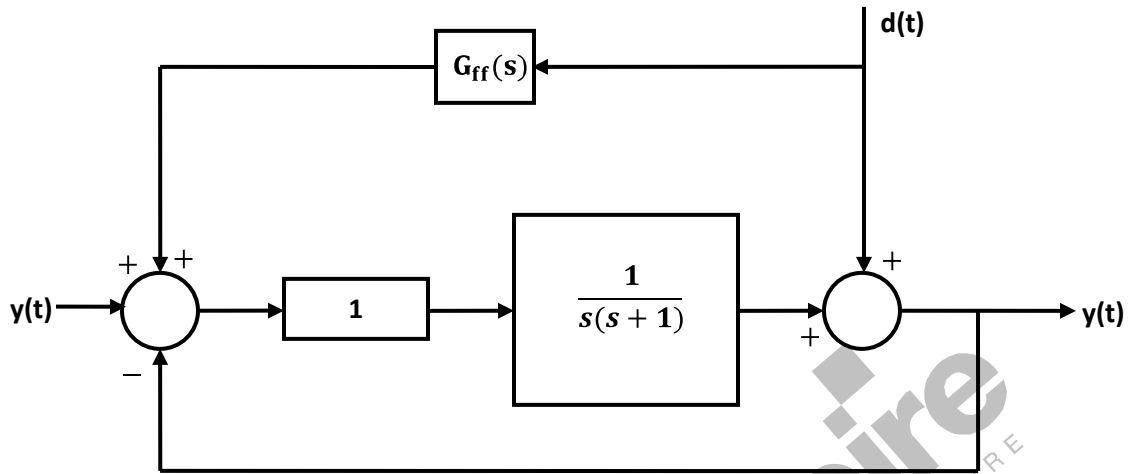

57. If the disturbance is measurable, its effect on the output can be minimized significantly using a feedforward controller $G_{ff}(s)$. To eliminate the component of the output due to $d(t) = \sin t$,

$G_{ff}(j\omega)|_{\omega=1}$ should be

- (A) $\frac{1}{\sqrt{2}} \angle -\frac{3\pi}{4}$
 (B) $\frac{1}{\sqrt{2}} \angle \frac{\pi}{4}$
 (C) $\sqrt{2} \angle \pi$
 (D) $\sqrt{2} \angle -\frac{\pi}{4}$

58. Let $G_{ff}(s)$ be a PD controller. If $d(t) = \sin 2t$, the amplitude of the frequency component of $y(t)$ due to $d(t)$ is

- (A) $\sqrt{\frac{5}{13}}$ (C) $\sqrt{\frac{17}{13}}$
 (B) $\sqrt{\frac{9}{13}}$ (D) $\sqrt{\frac{20}{13}}$

Statement for Linked Answer Questions 59 and 60:

A Michelson interferometer illuminated with a source of central wavelength λ_0 and spectral width of $\Delta\lambda$ is adjusted for equal path difference for the beams returning from the two mirrors. When one of the mirrors is moved by a distance of 0.1mm from this position, 300 fringes move past the field of view. When the mirror is moved further, the fringes completely disappear when the mirror is approximately 4cm from the initial position.

59. The central wavelength of the source is

- (A) 540nm
(B) 632.8nm

- (C) 667nm
(D) 720nm

60. The spectral width of the source $\Delta \lambda$ is approximately

- (A) 0.0056nm
(B) 0.0100nm

- (C) 0.0500nm
(D) 0.1000nm

